

TecnoRampa™



CERTIFIED COMPANY



Hydraulic dock leveler

USER MANUAL

tecnorampa.us

□ table of contents

	SUBJECT	PAGE
1	SEE SHIPPING NOTICE	2
2	OWNER'S PURCHASE RECORD	2
3	INTRODUCTION	3
	3.1 WARRANTY	3
	3.2 EXCLUSION OF WARRANTY	3
	3.3 OWNER'S LIABILITY	3
4	SAFETY WARNINGS	4
	4.1 IDENTIFICATION OF COLORS ON SAFETY SIGNS AND SAFETY MESSAGES	4
5	SAFE PRACTICES	5
6	PIT INSTALLATION REQUIREMENTS	6
7	INSTALLATION	8
	7.1 ITEMS TO CHECK BEFORE UNLOADING AND INSTALLATION	8
	7.2 INSTALLATION PROCESS	8
8	MODE OF OPERATION	10
	8.1 LIFTING THE LEVELER	10
	8.2 PLACING THE LEVELER IN THE REST POSITION	11
9	EQUIPMENT MAINTENANCE	12
	9.1 PREVENTIVE MAINTENANCE	12
	9.2 CHECKLIST OF INSPECTION PROCEDURES PRIOR TO OPERATING THE DOCK	14
	9.3 TROUBLESHOOTING GUIDE	14
	9.4 HYDRAULIC LEVELER ADJUSTMENTS	15
	9.4.1 MAINTENANCE BAR	16
	9.4.2 DECREASING PLATFORM LOWERING SPEED.	18
	9.4.3 INCREASED PLATFORM LOWERING SPEED.	18
	9.4.4 DECREASE IN LIP LOWERING SPEED.	18
	9.4.5 LIP LOWERING SPEED INCREASE.	19
	9.4.6 INCREASING LIP UNFOLDING SPEED	19
	9.4.7 DECREASE IN LIP DEPLOYMENT SPEED	19
	9.4.8 ADJUSTING THE LIP LIMITING SCREW	20
	9.5 HYDRAULIC AND ELECTRICAL DIAGRAMS OF H.U.	20
	9.5.1 ELECTRICAL DIAGRAM	20
	9.5.2 DIAGRAM OF HYDRAULIC UNIT	21
10	PARTS INVENTORY	22
	10.1 HYDRAULIC LEVELER HYDRAULIC SYSTEM DETAIL	23
	10.2 HYDRAULIC LEVELER PARTS EXPLOSION	24
	10.3 HYDRAULIC LEVELER PARTS LIST	25
	10.4 SPARE PARTS	26
	10.5 MECHANICAL PLATFORM RAMP DECAL	27
	10.6 VISUAL AID MECHANICAL PLATFORM RAMP DECALS	28

1. See shipping notice

CHECK SHIPPING BEFORE INSTALLATION

The Hydraulic Platform Dock Leveler has been carefully inspected at the manufacturing plant prior to shipment. To ensure that no damage has occurred during shipment, the dock leveler should be inspected upon receipt for shipping damage and to ensure proper operation. Damage due to shipping damage should be noted on the signed copy of the shipping document. The carrier must be notified of any damage within 48 hours of delivery.

NOTE

IF ANY DAMAGE IS DETECTED IN THE EQUIPMENT RECEIVED, YOU SHOULD CONTACT THE MANUFACTURER FOR VALIDATION OF THE EQUIPMENT.

2. Owner's purchase record

OWNER'S PURCHASE REGISTRATION

DEALER:

DATE OF SERVICE:

OWNER:

NUMBER OF UNITS:

ORDER NUMBER:

YEAR BUILT:

SERIAL NUMBER:

MODEL:

TECNORAMPA has a complete line of platform levelers, parking ramps, freight elevators and accessories. In accordance with the policy of continuous improvement in its product line, specifications and operating instructions are subject to change/modification without prior notification.

Descriptions and illustrations included in our operating instructions are not binding. Please contact Tecnorampa for the latest product information, or visit our website <https://www.tecnorampa.com.mx/> for the most current product information.

3. Introduction

▶ 3.1 WARRANTY

Tecnorampa warrants by and for the sole benefit of the original purchaser of the manufactured platform leveler that the Product will be free from defects in materials and workmanship, subject to the following express provisions: Base Warranty: all products are warranted for a base period of 2 years (“Base Warranty Period”) from the earlier of the date of installation approved by Tecnorampa or the sixtieth (60th) day after the date of shipment.

Mainspring Warranty: All mainsprings are warranted to cover the cost of replacement parts only for a period of (2) years. Parts and Assembly Warranty:

All spare or replacement parts are warranted to cover the cost of replacement parts and freight only for forty-five (45) days from the date of shipment.

▶ 3.2 WARRANTY DISCLAIMER

The foregoing warranties apply in lieu of any other warranties, whether express or implied, including, but not limited to, any implied warranty or merchantability for a particular purpose.

This Limited Warranty shall be null and void (i) if a Product is altered or modified from its original condition as installed or delivered at or from the factory, (ii) to the extent the defect in the Product is the direct result of improper installation, operation beyond the capability or not in accordance with Tecnorampa’s instructions, careless or negligent use, or failure to maintain the Product as recommended by Tecnorampa or (iii) if the original purchaser fails to notify Tecnorampa of the defect within sixty (60) days after the defect is discovered.

In no event shall Tecnorampa be liable to anyone, including third parties, for special, indirect, collateral, punitive, incidental or consequential damages, even if Tecnorampa has been advised of the possibility of such damages. Such excluded damages include, but are not limited to, loss of goodwill, loss of profits, loss of use, business interruption or other similar indirect financial loss.

▶ 3.3 OWNER’S RESPONSIBILITY

The owner must recognize the inherent danger of the interface between the transport vehicle and the leveler. The owner must train and instruct operators in the safe use of the platform dock leveler. Inspection procedures and periodic maintenance procedures recommended by the manufacturer must be followed.

The owner must ensure that all safety labels and instructions are posted on the leveler and are legible to the operator or maintenance personnel for whom these warnings are intended, as well as ensure that the appropriate operating and maintenance manuals are provided to the users.

Levelers that are structurally damaged or have suffered a loss of support under load, which may occur when a transport vehicle is removed under the platform leveler, should be removed from service, inspected by an authorized representative of the manufacturer and repaired as necessary before being returned to service.

When a transport vehicle is positioned for loading and unloading, there must be a contact surface of at least 4” (100mm) between the leading edge of the lip of the leveler and the edge of the floor of the loading vehicle. When a vehicle is being driven on and off the transport vehicle during the loading and unloading operation through the platform leveler, the brakes of the transport vehicle must be applied and the wheels must be chocked with an appropriate wheel chock or using a vehicle restraint system.

During the loading and unloading operation, do not exceed 6.5 km/h when driving over the leveler.

The leveler should never be used outside its vertical working range or vertical lifting range or outside the rated capacity established by the manufacturer.

4. Safety warnings

Improper operation can cause accidents. Do not take chances with incorrect or damaged equipment. Read and understand the procedures for safe operation and maintenance described in this manual. Do not hesitate to ask for help.

Stay alert! Follow safety rules, regulations and procedures. Avoid accidents by recognizing dangerous procedures or situations before they occur.

Safety signs and messages are placed in this manual to provide instructions and identify specific areas where potential hazards exist and special precautions should be taken. Knowing and understanding the meaning of these instructions, signs and messages can prevent and avoid damage to equipment, death or serious injury to yourself or others.

4.1 COLOR IDENTIFICATION OF SAFETY SIGNS AND SAFETY MESSAGES

This manual includes color-coded safety messages to identify instructions and specify areas where potential hazards exist.



This is the safety alert symbol. It is used to alert you to potential personal injury hazards. Obey all safety messages containing this symbol to avoid possible serious or fatal injury. The following is the color code established in this manual for safety messages.



DANGER

THIS MESSAGE INDICATES AN IMMINENT DANGER SITUATION WHICH, IF NOT AVOIDED, WILL RESULT IN DEATH OR SERIOUS HARM.



WARNING

THIS MESSAGE INDICATES A POTENTIALLY HAZARDOUS SITUATION WHICH, IF NOT AVOIDED, COULD RESULT IN DEATH OR SERIOUS INJURY.



CAUTION

THIS MESSAGE INDICATES A POTENTIALLY HAZARDOUS SITUATION WHICH, IF NOT AVOIDED, MAY RESULT IN MINOR OR MODERATE INJURY.



IMPORTANT

THIS MESSAGE IS USED WHEN SPECIAL PRECAUTIONS ARE IN PLACE AND MUST BE TAKEN TO ENSURE CORRECT ACTION OR TO PREVENT DAMAGE OR MALFUNCTION OF THE EQUIPMENT AND/OR A COMPONENT.

□ 5. Safe practices

The following is intended to be a quick reference to some of the important procedures that should be followed when using the platform dock leveler. It is not intended to cover, nor does it suggest that it does, all procedures that must be followed to ensure safe operation. Operators should be aware of and comply with all workplace safety regulations that may apply to the operation of the platform dock leveler.



WARNING

1. Do not install, operate and/or service this leveler unless you have been trained and authorized to do so.
2. Do not install, operate and/or service this leveler until you have read and understand all safety information and instructions contained in this manual.
3. Do not operate this leveler until you have verified its condition. Report the need for repairs to your supervisor immediately and do not operate the leveler until repairs are made. Negligence can turn a minor repair into a major service problem and make the leveler unsafe.
4. Do not work under or around the leveler being installed without first placing adequate barriers to prevent vehicle traffic from entering the work area.
5. All electrical wiring, connections, repairs and troubleshooting must be performed by qualified service personnel.
6. All wiring connections and repairs must be made to comply with all applicable codes. Before performing any electrical work, make sure the power is disconnected and properly tagged and/or locked out.
7. Before performing any maintenance, secure the platform leveler properly.
8. Do not load the leveler beyond the capacity shown on the leveler serial nameplate.
9. Stand clear of the platform leveler and the vehicle when the vehicle is backing up or leaving the platform area.
10. Secure the vehicle by chocking the vehicle wheels or using a vehicle restraint system before operating the platform leveler.
11. Do not use or move the platform leveler if someone is under, in front of, and/or on the platform leveler.
12. Keep hands and feet away from the platform leveler attachment points at all times. Never use your hands to lift the platform ramp and/or the edge of the vehicle or to put the platform leveler away.
13. Do not drive over the leveler unless the edge is firmly in contact on the vehicle platform and has a minimum projection of 4" (100 mm) onto the vehicle platform.
14. Do not exceed the stated weight of the leveler when in use.
15. Do not drive over the edges of the leveler and/or the platform bumpers (bumpers are not structural).
16. Do not leave equipment or materials unattended on the leveler.
17. Do not leave the leveler unattended in the deployed position.
18. Do not use a forklift or other material handling equipment to lower the platform leveler.
19. Never attempt to make repairs. Refer to a qualified repair technician.
20. Use safety equipment as required.
21. Practical workplace guidance for the safe use of this product may restrict the use of any substance that may compromise or impair safe operational use.

This manual is intended to be readily available. Keep it near the leveler as a reference for anyone who may operate or repair it. If the leveler you are operating is not equipped with a manual, ask to obtain one and locate it near the leveler.

6. Pit installation requirements



IMPORTANT

READ THE ENTIRE INSTALLATION AND OPERATION MANUAL BEFORE INSTALLING OR OPERATING THE RAMP.

DO NOT INSTALL THE RAMP ON ANY SURFACE OTHER THAN CONCRETE, CONFIRMING THAT IT MEETS THE MINIMUM SPECIFICATIONS.

TECHNICAL DETAILS OF THE PIT

NOMINAL DIMENSIONS:

PIT WIDTH (W):
74" (1880MM)

PIT LENGTH (L):
85-1/4" (2165MM)

PIT HEIGHT (H1 AND H2): H1(REAR HEIGHT):
19-1/2" (495MM) H2(FRONT HEIGHT): 20" (508MM)

PIT MATERIAL:
CONCRETE WITH A STRENGTH OF 250KG/CM2 WITH AT
LEAST 15CM (6") THICK

ANGLE OF PIT EDGES: 3" X 3" X 1/4" ANGLE

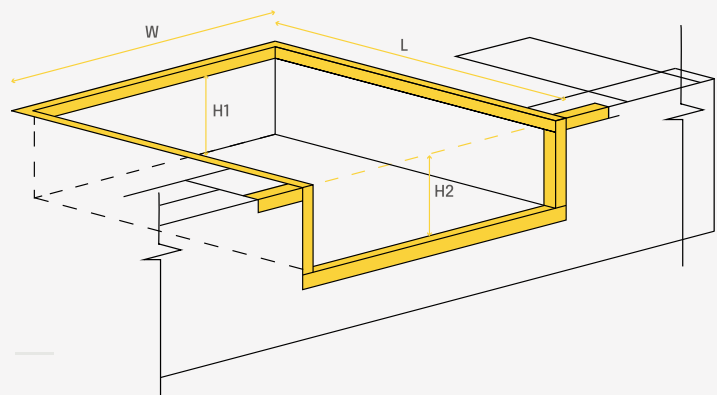

TECHNICAL DETAILS OF LEVELER

	MODEL OF LEVELER		
	RNH306X816	RNH406X816	RNH506X816
RATED CAPACITY	30,000 LBS	40,000 LBS	50,000 LBS
RATED DIMENSIONS	6'X8' (1829MM X 2438MM)	6'X8' (1829MM X 2438MM)	6'X8' (1829MM X 2438MM)
PLATFORM DIMENSIONS	72" X 83-3/8" (1829MM X 2118MM)	72" X 83-3/8" (1829MM X 2118MM)	72" X 83-3/8" (1829MM X 2118MM)
LEVELING	+/- 12" WITH RESPECT TO PLATFORM LEVEL	+/- 12" WITH RESPECT TO PLATFORM LEVEL	+/- 12" WITH RESPECT TO PLATFORM LEVEL
STANDARD LIP	16",18",20",22"	16",18",20",22"	16",18",20",22"
OPERATION SYSTEM	HYDRAULIC	HYDRAULIC	HYDRAULIC
FINISH	LEAD GREY/YELLOW	LEAD GREY/YELLOW	LEAD GREY/YELLOW

LEVELER MODEL BREAKDOWN

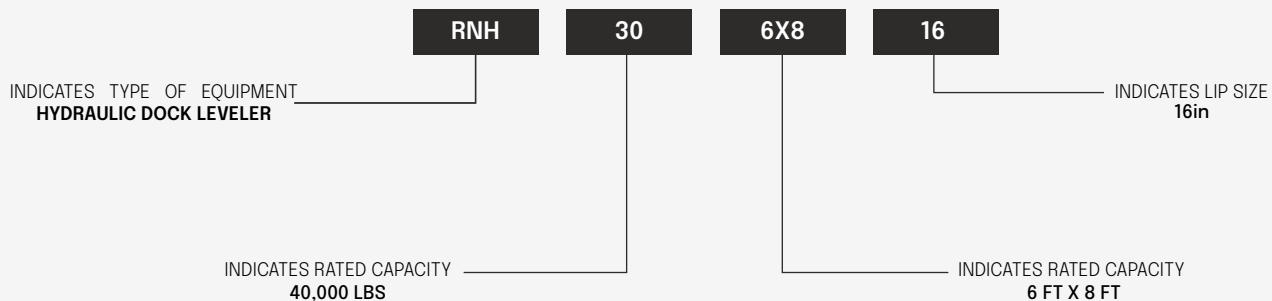

SIZES AVAILABLE IN HYDRAULIC DOCK LEVELERS

NOMINAL CAPACITIES (LBS)	LIP SIZES (IN)	NOMINAL DIMENSIONS (FT)
30,000	16	6X8
40,000	20	
50,000		

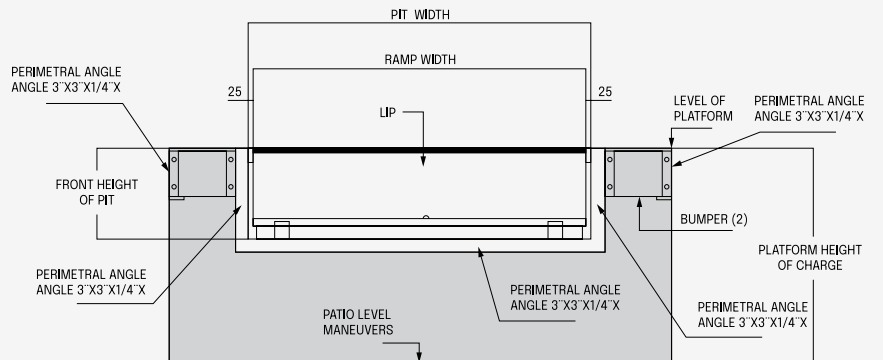
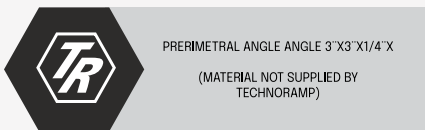

7. Installation

7.1 POINTS TO REVIEW BEFORE UNLOADING AND INSTALLING

▶ Pit dimensions

Always use architectural plans when they are available. Check the dimensions of the pit area, to make sure that such a space is suitable and the required space is available.

▶ Type of concrete

The ramps must be installed in concrete with a resistance of 250 kg/cm² with a minimum of 15cm (6") thick. If the concrete installed does not comply with at least this specification inform the personnel in charge and do not proceed with the installation of the leveler.

▶ Defective concrete

Visually inspect the area where the ramp will be installed and check for cracks or defects in the Concrete. In case of detecting any defect on the concrete, inform the supervisor or personnel in charge of the finding and do not proceed with the installation until the necessary repairs have been made.

7.2 INSTALLATION PROCESS

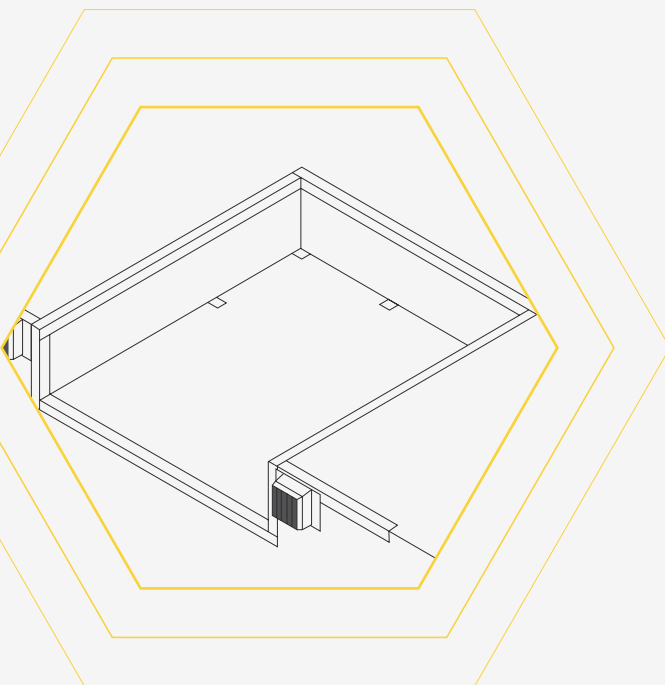

- 1 Unload the ramp and place it near the area where you will try to install it.
- 2 Remove the shipping bands and packing material from the unit.
- 3 Remove the packaging supports.
- 4 Check the quantity of all components with the parts list. If there are missing parts, please contact your ramp supplier.
- 5 Next, measure the depth of the rear corners of the platform pit and do the same with the front corners of the pit.
- 6 Place plate and sheet metal shims to match the height of the rear frame of the grader with the rear edge of the pit as shown.

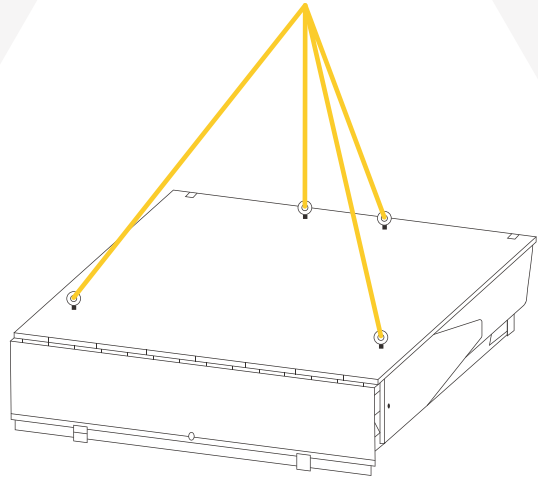
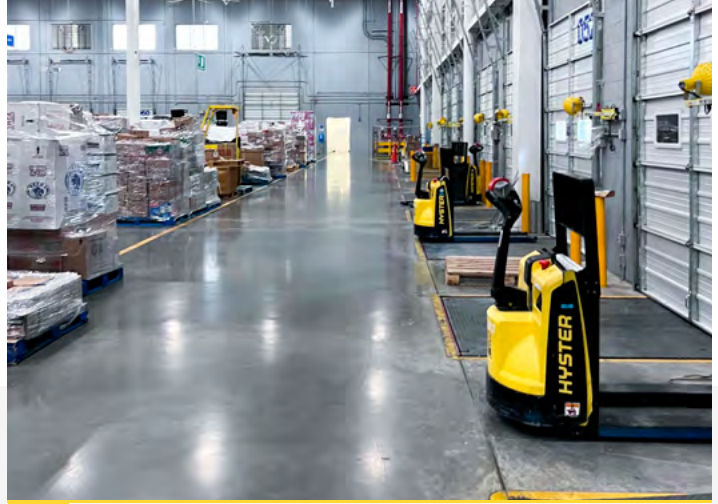

- 7 Using slings or chains for a minimum capacity of 1000 Kg, lift the ramp from the appropriate attachment points as shown below and carefully position it inside the pit. Make sure that the gap between the sides of the grader and the sides of the pit is equal. Also, check that the positioned shims are suitable for leveling the rear edges of the pit and leveler. Add or remove shims as needed.

- 8 Next, release the front lip clamping screw and pull the drive chain slightly to allow the platform to be raised slightly without actuating the lip mechanism.

- 9 Walk on the platform to return the leveler to its stored position making sure that the lip rests correctly on the front supports.

- 10 Check the front height of the platform and adjust the height with shims if required.
Note: It is recommended that the front of the leveler is always below the platform level.

- 11 Carefully inspect that the rear frame is perfectly aligned with the perimeter angle from the pit. Add or remove shims as needed.

- 12 Also inspect the height and front alignment of the ramp. Add or remove shims as needed.

- 13 Proceed to welding the rear and front frames to secure the leveler in position. Use 1/8" 7018 weld to apply evenly spaced weld beads on the contact surface between the rear frame of the leveler and the perimeter angle of the pit. Do the same with the contact surface between the face plate of the leveler base and the front angle of the pit.

- 14 If necessary make the necessary adjustments following the instructions in Section 9.4 HYDRAULIC LEVELER ADJUSTMENTS.

8. Form of operation



WARNING

BEFORE OPERATING THE PLATFORM LEVELER, ALWAYS IMMOBILIZE THE TRUCK WITH A RETAINER OR WHEEL CHOCKS.
DO NOT OPERATE THE PLATFORM LEVELER IF THERE IS SOMEONE STANDING ON IT OR IN FRONT OF IT.
DO NOT MANUALLY RAISE THE LEVELER LIP.
ALWAYS KEEP YOUR HANDS AND FEET AWAY FROM MOVING PARTS.
AFTER SERVICING THE TRUCK, ALWAYS RETURN THE LEVELER TO THE SAFE POSITION AT THE PLATFORM LEVEL, WITH THE LIP HELD IN THE CORRESPONDING LOCKS.
DO NOT DRIVE ON THE LEVELER UNLESS THE EDGE IS FIRMLY IN CONTACT ON THE VEHICLE PLATFORM AND HAVE A MINIMUM PROJECTION OF 4" (100 MM) ON THE VEHICLE PLATFORM.
DO NOT OPERATE THE LEVELER ABOVE ITS SET CAPACITY. DO NOT EXCEED 6.5 KM/H WHEN DRIVING ON THE LEVELER.
DO NOT DRIVE OVER THE EDGES OF THE LEVELER AND/OR THE PLATFORM STOPS (THE STOPS ARE NOT STRUCTURAL).

8.1 LEVELER LIFTING

1.

Before operating the platform leveler, immobilize the truck with a retainer or wedges on the wheels

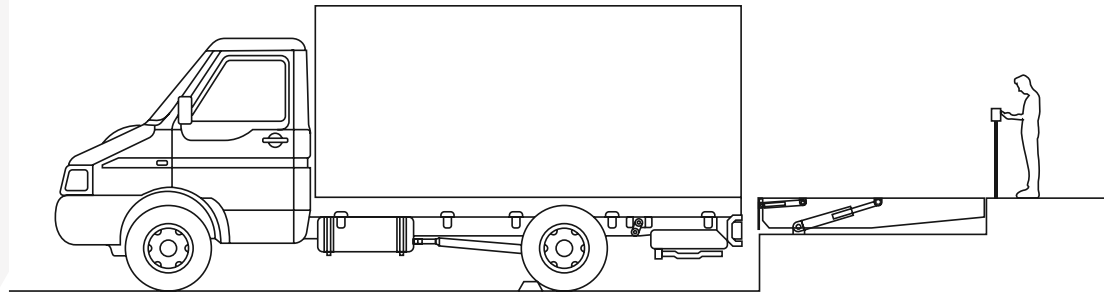

2.

To raise the leveler, activate the leveler by pressing and holding the RAISE button until the leveler is fully raised and the lip is fully extended.

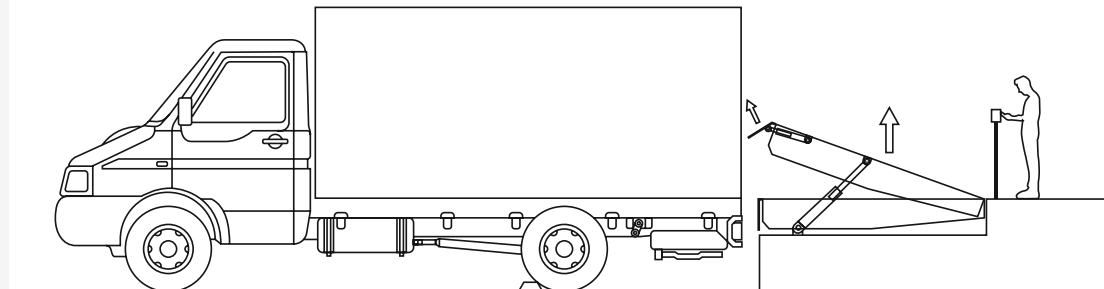

WARNING

IF THE LIP DOES NOT EXTEND FULLY, DO NOT ATTEMPT TO RAISE IT MANUALLY. BRING THE LEVELER BACK TO PLATFORM LEVEL AND TRY AGAIN. IF THE LIP DOES NOT EXTEND FULLY, THE PLATFORM LEVELER NEEDS MAINTENANCE OR ADJUSTMENT. NOTIFY YOUR SUPERVISOR. DO NOT USE THE LEVELER UNTIL IT IS REPAIRED. FAILURE TO DO SO COULD RESULT IN SERIOUS OR FATAL INJURY.



3.

When the lip is fully extended, release the LIFT button. The leveler will automatically lower to the truck/trailer bed.

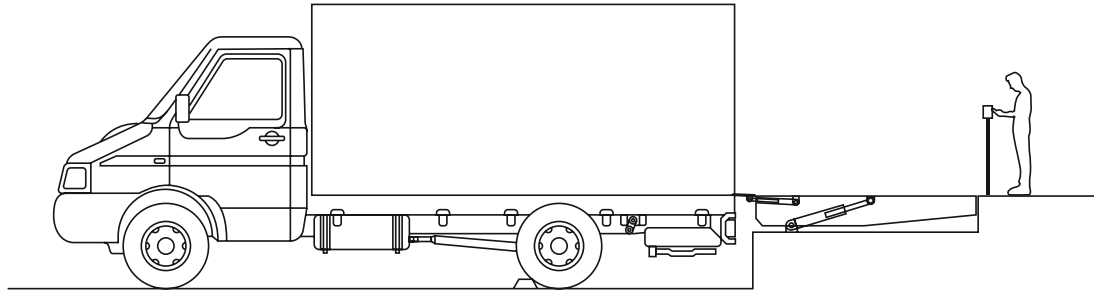

WARNING

IF THE LIP IS ON THE EDGE OF THE TRUCK/TRAILER AND THE TRUCK PULLS OUT, THE LEVELER WILL MOVE TO ITS LOWEST POSITION AND THE LIP WILL BEGIN TO LOWER.

▶ 8.2 PLACE LEVELER IN THE REST POSITION

1.

To store the leveler, press and hold the LIFT button until the leveler is approximately 6 inches above the level of the platform and the lip is fully retracted.

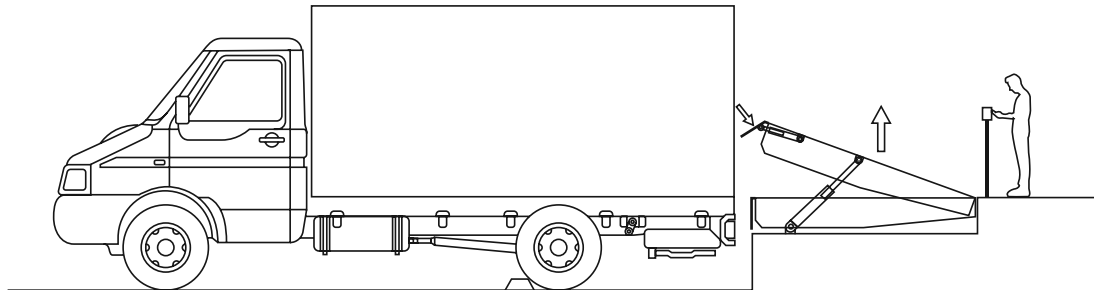

2.

Release the RAISE button. The leveler will lower to platform level with the edge resting on the lip supports.

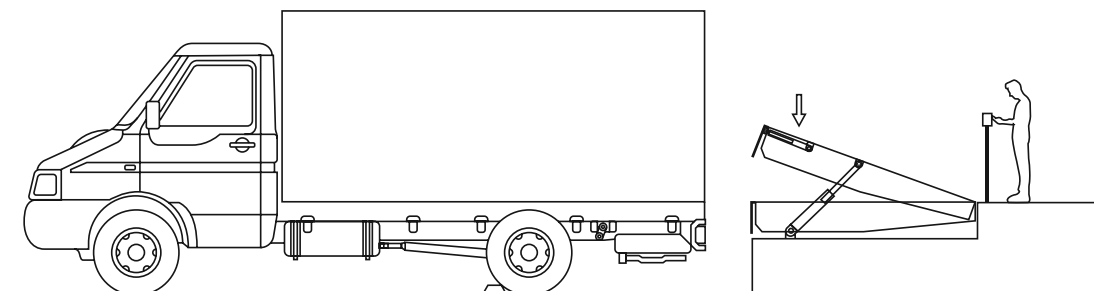

9. Maintenance of the equipment



DANGER

Before installation/maintenance/adjustment, place suitable barriers to prevent unauthorized personnel and vehicle traffic from entering the work area.



DANGER

Before carrying out any adjustment work, place the maintenance baton in position



WARNING

All repairs and maintenance work must be performed only by trained and authorized personnel.

▶ 9.1 PREVENTIVE MAINTENANCE

Every 10 days of operation check the following points:

- ▶ Check for traces of materials on the lip hinge. Clean it as needed.
- ▶ Check for material debris in the area of the leveler's rear hinge and between the sides and edge angles, to ensure proper operation. Clean them as needed.
- ▶ Check the safety baton system to make sure it is working properly and has no structural defects, pull the chain and check the operation of the recoil spring.
- ▶ Check the operation of the foot guards to make sure that they are not deformed or jammed when the leveler is used.
- ▶ Check that the bolts have their cotter pin in place. Do not operate the ramp if any of the bolts do not have their insurance. Replace them if necessary.
- ▶ Check that the platform stops are present.

Every three months or every 250 hours of operation:

- ▶ Clean the inside of the pit area.
- ▶ Check all for proper operation of the leveler.
- ▶ Inspect the following items for damage/abnormal wear:
 - Check welding for flaws or fatigue. Pay particular attention to hinges, top plate beams and front hinge bar.
 - Cylinder bolts and mounting holes.
 - Lip and platform hinge bolts.
 - Check side guards for free movement.
 - Inspect hoses, cylinders, hydraulic connections and power unit.
 - Inspect control box and conduit for damage..
 - Check if the pusher Trolley assemblies and its roller are damaged.
- ▶ Check all labels and warning signs. Replace as necessary.
- ▶ Check platform stops. If they are worn or missing, replace them.
- ▶ Lubricate the following areas:
 - a. Lip hinges through installed grease fittings (Maintenance stick in position to perform this operation). Do not over grease. Stop greasing when grease begins to flow from the ends of the hinge tube. Wipe off excess grease with a cloth.
 - b. Platform hinge area (apply oil to the entire length of the platform hinge when the platform is at maximum level below ground level).
 - c. Lift cylinder to platform frame pin.
 - d. Lift cylinder to base frame pin.
 - e. Lip cylinder to platform frame pin.
 - f. Lip clevis to lip cylinder pin.

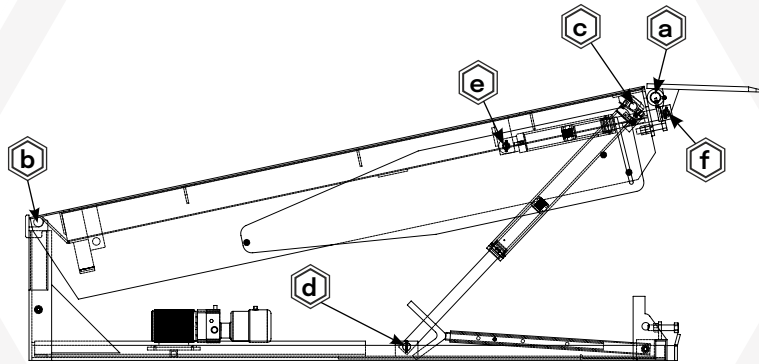

DIAGRAM OF AREAS TO BE LUBRICATED

Semi-Annual Maintenance:

- ▶ Pit cleaning.
- ▶ Re-tightening of hydraulic system connections.
- ▶ Cleaning of hydraulic cylinders and reservoir for fluid evaporation.
- ▶ Inspection of side brushes (if equipped).

Annual Maintenance:

- ▶ Complete quarterly and semi-annual maintenance.
- ▶ Check fluid level in the reservoir tank:
 1. Place the platform in position with the maintenance sticks.
 2. Turn off all electrical power to the dock leveler.
 3. Remove the breather cap from the reservoir tank.
 4. Measure the fluid level.
 5. Add hydraulic fluid if needed. Use only the recommended hydraulic fluid (ISO 68).
 6. Replace the reservoir tank breather cap.
 7. Turn on the electrical power supply of the dock leveler.
 8. Remove safety poles and return the platform to the stowed position.

▶ 9.2 CHECKLIST OF INSPECTION PROCEDURES BEFORE OPERATING THE RAMP



WARNING

All repairs and maintenance work must be performed ONLY by trained and authorized personnel.



DANGER

Prior to installation/maintenance/adjustment, place adequate barriers to prevent unauthorized personnel and vehicular traffic from entering the work area. Before performing any adjustment work place the maintenance rod in position.

HIDRAULIC DOCK LEVELER

Serial number _____

Platform # _____

Date _____

Instructions:

Use the [✓] mark in the appropriate box of each inspection point to indicate that it is in optimal condition for use.

Use the [x] mark in the appropriate box of each inspection point to indicate that it is not in optimal condition.

Every day (Can be performed by owner or assistant):

- Check for material debris in the rear hinge area of the leveler and between the sides and edge angles to ensure smooth operation.
- Verify that the platform dock leveler operates smoothly.
- Check that the platform stops are present.
- Check the platform for irregularities such as cracks in the concrete.
- Verify that the work area around the platform is clear. Eliminate any potential tripping hazards.
- Verify the interior and exterior lighting system and external signage is present and legible (if equipped).
- Check that wheel chocks or vehicle restraint system are in good working condition.

Explain the failures briefly in the space provided below:

Name of person in charge of Inspection



WARNING

Do not attempt to perform installation, repair, maintenance or adjustment work. Such work should be performed **ONLY** by trained and authorized personnel. Contact your local distributor for assistance.

PROBLEM	POSSIBLE CAUSE	PROBLEM SOLUTION
The platform does not rise	<ol style="list-style-type: none"> 1. The power supply has been disconnected. 2. The motor has been incorrectly connected 3. The hydraulic fluid level in the reservoir is too low. 4. There could be leaks in the connection of the platform cylinder 5. Foreign material may be jammed between the platform side and the pit wall or in the platform hinge. 6. Platform bumpers could be damaged or missing, allowing the truck to contact and stop the lip. 	<ol style="list-style-type: none"> 1. Verify that the power supply has not been disconnected. Check the operation of the control system. 2. Verify that the motor has been connected according to the motor connection diagram 3. Check the oil level with the unit raised and the maintenance stick in place. Top up if necessary. 4. Check the platform cylinder connection for leaks. 5. Inspect the pit sides and platform hinge, remove material that could affect operation. 6. Replace damaged or missing platform stops.
The lip extends very slowly and/or does not extend.	<ol style="list-style-type: none"> 1. Lip cylinder valve on the hydraulic unit may be out of adjustment. 2. Leakage at the lip cylinder connection. 3. There could be a low hydraulic fluid level. 4. There could be foreign material stuck in the lip hinges. 5. Lip may be bent. 	<ol style="list-style-type: none"> 1. Adjust the hydraulic valve pressure to the required level. See the procedure in section 9.4.6 and 9.4.7. 2. Check the connection of the cylinder and the hydraulic unit. 3. Check the oil level with the unit raised and the maintenance stick in place. Top up if necessary. 4. Inspect the lip hinges and remove any material that impedes the lip operation. 5. Lubricate according to the maintenance procedure or replace the lip.
The platform does not go down	<ol style="list-style-type: none"> 1. There could be foreign material jammed underneath, on the sides or on the rear hinge of the platform. 2. The needle valve to regulate the speed of fall may require adjustment. 	<ol style="list-style-type: none"> 1. Visually inspect and remove any foreign material that could prevent the platform from operating properly. 2. Adjust the needle valve according to the appropriate procedure. See procedure in section 9.4.3.

PROBLEM	POSSIBLE CAUSE	PROBLEM SOLUTION
The platform rises very slowly.	<ol style="list-style-type: none"> 1. There may be a load on the platform. 2. Hydraulic fluid level is low. 3. Low operating voltage. 4. Faults in the power unit/pump/motor. 5. Foreign material may be jammed between the side of the platform and the pit wall or in the platform hinge. 	<ol style="list-style-type: none"> 1. Remove any external load from on top of the platform. 2. Check the oil level with the unit raised and the maintenance stick in place. Top up if necessary. 3. Check the operating voltage when the ramp is in operation. 4. Repair or replace damaged components as necessary. 5. Inspect the pit sides and platform hinge, remove material that could affect operation.
When the leveler lowers, the lip lowers very fast and does not deploy in the vehicle bed.	<ol style="list-style-type: none"> 1. Needle valves to regulate the rate of fall may require adjustment. 	<ol style="list-style-type: none"> 1. Adjust the needle valve of the lip cylinder according to the corresponding procedure. See procedure in section 9.4.4.
The platform and lip descend very slowly to the bed of the vehicle.	<ol style="list-style-type: none"> 1. Needle valves to regulate drop speed may require adjustment. 2. Foreign material may be jammed in the platform and lip hinges. 	<ol style="list-style-type: none"> 1. Adjust the needle valves of the cylinders according to the corresponding procedure. See procedures in section 9.4.3 and 9.4.5. 2. Visually inspect and remove any material that could impede the proper operation of the platform and lip.
The platform rises very slowly.	<ol style="list-style-type: none"> 1. There may be a load on the platform. 2. Hydraulic fluid level is low. 3. Low operating voltage. 4. Faults in the power unit/pump/motor. 5. Foreign material may be jammed between the side of the platform and the pit wall or in the platform hinge. 	<ol style="list-style-type: none"> 1. Remove any external load from on top of the platform. 2. Check the oil level with the unit raised and the maintenance stick in place. Top up if necessary. 3. Check the operating voltage when the ramp is in operation. 4. Repair or replace damaged components as necessary. 5. Inspect the pit sides and platform hinge, remove material that could affect operation.
When the leveler lowers, the lip lowers very fast and does not deploy in the vehicle bed.	Needle valves to regulate the rate of fall may require adjustment.	<ol style="list-style-type: none"> 1. Adjust the needle valve of the lip cylinder according to the corresponding procedure. See procedure in section 9.4.4.
The platform and lip descend very slowly to the bed of the vehicle.	<ol style="list-style-type: none"> 1. Needle valves to regulate drop speed may require adjustment. 2. Foreign material may be jammed in the platform and lip hinges. 	<ol style="list-style-type: none"> 1. Adjust the needle valves of the cylinders according to the corresponding procedure. See procedures in section 9.4.3 and 9.4.5. 2. Visually inspect and remove any material that could impede the proper operation of the platform and lip.

PROBLEM

POSSIBLE CAUSE

PROBLEM SOLUTION

The lip is not completely stored in its stored position.

1. Foreign material may be preventing the lip plate from stowing properly.
2. Needle valves to regulate drop rate may require adjustment.
3. The lip limiting screw-stopper is not adjusted correctly.

1. 1.- Check that there are no objects interfering with the mechanism that prevent the lip from closing.
2. Adjust the lip cylinder needle valve according to the corresponding procedure. See procedure in section 9.4.5.
3. Verify that the lip limiter stop screw adjustment is correct. Adjust according to the corresponding procedure in section 9.4.8.

The lip or platform does not reach its full open position when the start button is activated.

1. There could be foreign material preventing the lip plate and platform from deploying properly.
2. There could be a lack of oil for the correct deployment of the hydraulic cylinders.

1. Check that there is no external object interfering with the correct opening of the plates.
2. Check the oil level with the unit raised and the maintenance stick in place. Top up if necessary.

▶ 9.4 HYDRAULIC LEVELER SETTINGS



WARNING

DO NOT ATTEMPT TO PERFORM INSTALLATION, REPAIR, MAINTENANCE OR ADJUSTMENT WORK. SUCH WORK SHOULD BE CARRIED OUT ONLY BY TRAINED AND AUTHORIZED PERSONNEL. CONTACT YOUR LOCAL DISTRIBUTOR FOR ASSISTANCE.

▶ 9.4.1 MAINTENANCE BAR

1. To raise the maintenance bar :
 - a. Press the actuation button and bring the dock leveler to the maximum raised position. Pull the maintenance bar up and back.
 - b. Position the bar safety pin and drop it to the immobilized position.
 - c. immobilized position.

2. To bring the maintenance bar downward:
 - a. Remove the safety pin from the bar.
 - b. Pull the maintenance bar down and back. It will then lower to the

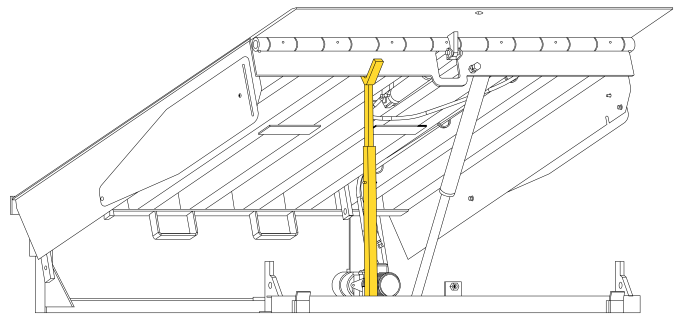

NOTE: Before making any adjustments check the oil level in the reservoir.

▶ 9.4.2 DECREASING PLATFORM LOWERING SPEED.

To slow down the lowering speed of the leveler platform follow the procedure.

- Locate the needle valve for platform cylinder adjustment.
- Using an appropriate Allen wrench, turn the valve clockwise.
- Make 1/4" turn adjustments and check operation each time until the desired rate of descent is obtained.

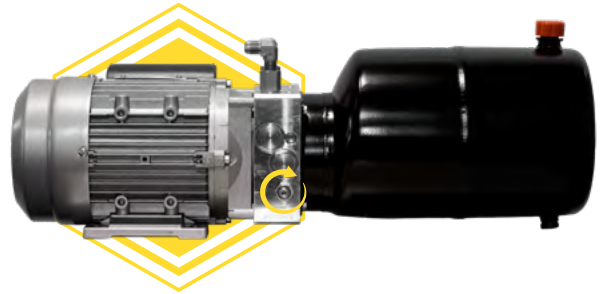

IMPORTANT

ADJUST THE POSITION OF THE NEEDLE VALVE ONLY AS LITTLE AS NECESSARY, TURNING THE VALVE TOO MUCH IN ONE DIRECTION OR THE OTHER MAY CAUSE DIFFICULTIES IN LOWERING THE PLATFORM.

▶ 9.4.3 INCREASED PLATFORM LOWERING SPEED.

To increase the lowering speed of the leveler platform follow the procedure.



- Locate the needle valve for platform cylinder adjustment.
- Using an appropriate Allen wrench, turn the valve counterclockwise.
- Make 1/4" turn adjustments and check operation each time until the desired rate of descent is obtained.



IMPORTANT

ADJUST THE NEEDLE VALVE POSITION ONLY AS LITTLE AS NECESSARY, TURNING THE VALVE TOO MUCH CAN CAUSE HYDRAULIC OIL LEAKAGE THROUGH THE NEEDLE VALVE.

▶ 9.4.4 DECREASE IN LIP LOWERING SPEED.

To slow down the lowering speed of the Leveler lip follow the procedure.

- Locate the lip cylinder adjustment needle valve.
- Using an appropriate Allen wrench, turn the valve clockwise.
- Make 1/4" turn adjustments and check operation each time until the desired rate of descent is obtained.

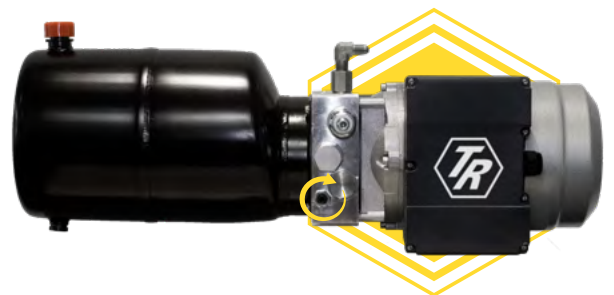

IMPORTANT

ADJUST THE NEEDLE VALVE POSITION ONLY AS LITTLE AS NECESSARY, TURNING THE VALVE TOO MUCH MAY CAUSE DIFFICULTIES IN LOWERING THE LIP.

▶ 9.4.5 LIP LOWERING SPEED INCREASE.

To increase the lowering speed of the leveler lip follow the procedure.

- Locate the lip cylinder adjustment needle valve.
- Using an appropriate Allen wrench, turn the valve counterclockwise.
- Make 1/4" turn adjustments and check operation each time until the desired rate of descent is obtained.

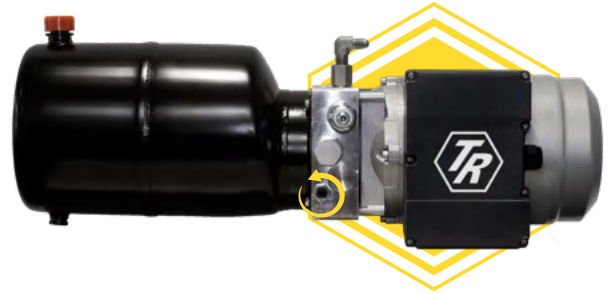

IMPORTANT

ADJUST THE NEEDLE VALVE POSITION ONLY AS LITTLE AS NECESSARY, TURNING THE VALVE TOO MUCH CAN CAUSE HYDRAULIC OIL LEAKAGE THROUGH THE NEEDLE VALVE.

▶ 9.4.6 INCREASING LIP UNFOLDING SPEED

The lip is set to deploy once the platform is fully raised. If the lip takes too long to deploy adjust the lip adjustment valve using the following procedure.

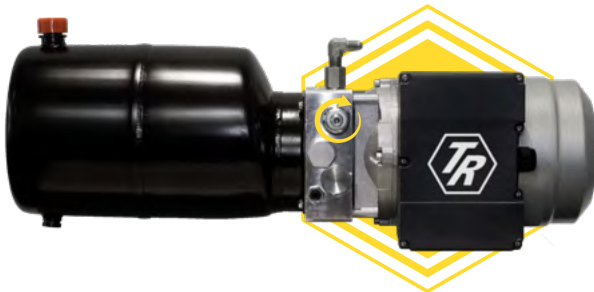

- Locate the valve to regulate the speed of deployment of the lip cylinder.
- Using an appropriate wrench, turn the valve counterclockwise.
- Make 1/4" turn adjustments and check operation each time until the desired deployment speed is obtained.



IMPORTANT

THIS VALVE IS PRESET AT THE FACTORY TO THE OPTIMUM LEVEL TO ALLOW FOR PROPER RAMP OPERATION. DO NOT ATTEMPT TO MAKE ADJUSTMENTS UNLESS YOU FULLY UNDERSTAND THE OPERATION OF THE RAMP'S HYDRAULIC SYSTEM, FAILURE TO DO SO MAY CAUSE PROBLEMS WITH THE RAMP'S OPERATING CYCLE.

▶ 9.4.7 DECREASE IN LIP DEPLOYMENT SPEED

The lip is set to deploy once the platform is fully raised. If the lip deploys before the platform is finished, adjust the lip adjustment valve using the following procedure.

- Locate the valve to regulate the lip cylinder deployment speed.
- Using an appropriate wrench, turn the valve clockwise.
- Make 1/4" turn adjustments and check operation each time until the desired deployment speed is obtained.

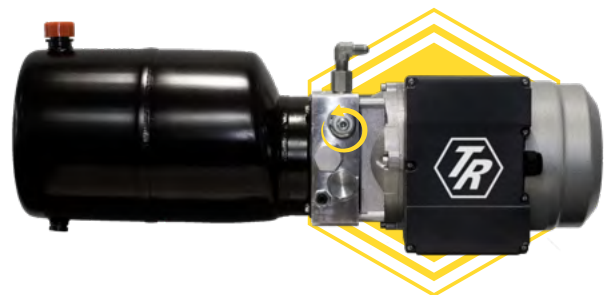

IMPORTANT

THIS VALVE IS PRESET AT THE FACTORY TO THE OPTIMUM LEVEL TO ALLOW FOR PROPER RAMP OPERATION. DO NOT ATTEMPT TO MAKE ADJUSTMENTS UNLESS YOU FULLY UNDERSTAND THE OPERATION OF THE RAMP'S HYDRAULIC SYSTEM, FAILURE TO DO SO MAY CAUSE PROBLEMS WITH THE RAMP'S OPERATING CYCLE.

9.4.8 ADJUSTING THE LIP LIMITING SCREW

The lip limiting screw has the function of limiting the lip drop and allowing it to be properly stored in the corresponding brackets at the front of the dock leveler. The screw is factory set to a distance within a range of 45mm to 55mm. Due to normal conditions of use or transportation it may require some adjustment to work properly.

To make adjustments to the screw follow the procedure described.

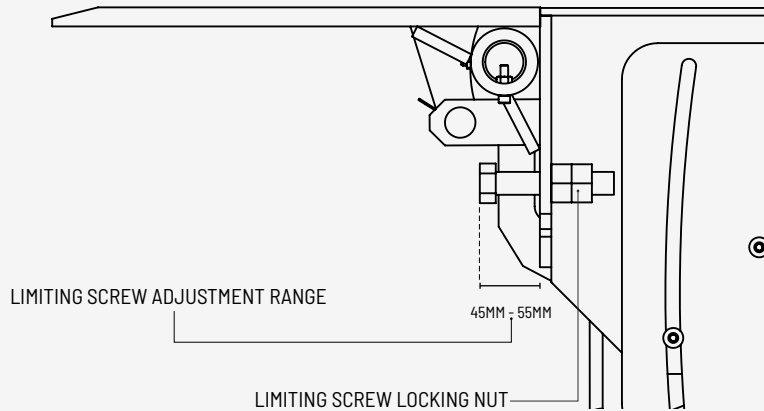

1. loosen the locking nut on the limiting screw.
2. Make 1 turn clockwise adjustments to the screw if you wish to decrease the lip clearance distance. Check operation each time.
3. Turn the screw counterclockwise 1 turn if you want to increase the lip clearance distance. Check operation each time.
4. Once the desired setting distance is achieved, retighten the locking nut on the limiting screw.

9.5 HYDRAULIC AND ELECTRICAL DIAGRAMS OF U.H.

9.5.1 ELECTRICAL DIAGRAM

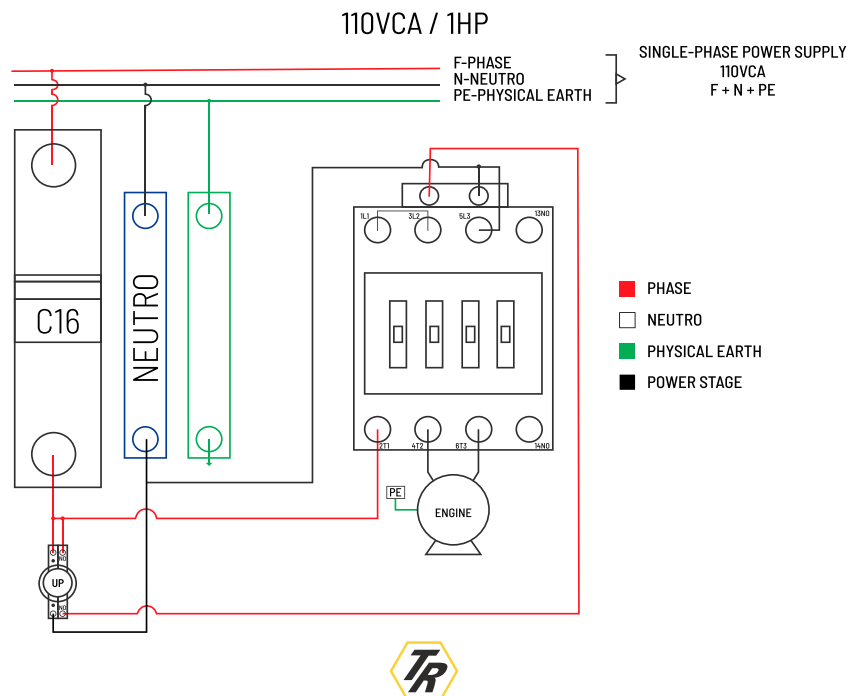

DESCRIPTION OF HYDRAULIC UNIT

HYDRAULIC UNIT	1HP
POWER SUPPLY	110 VCA
NUMBER OF PHASES	1 NEUTRO/1 PHYSICAL EARTH
AMPERS CONSUMPTION	16
WATTS CONSUMPTION	0.75 KW
OIL TYPE	ISO 68

9.5.2 DIAGRAM OF HYDRAULIC UNIT

1 HP Hydraulic Unit, 8 liter ISO 68 Hydraulic Oil Unit Reservoir

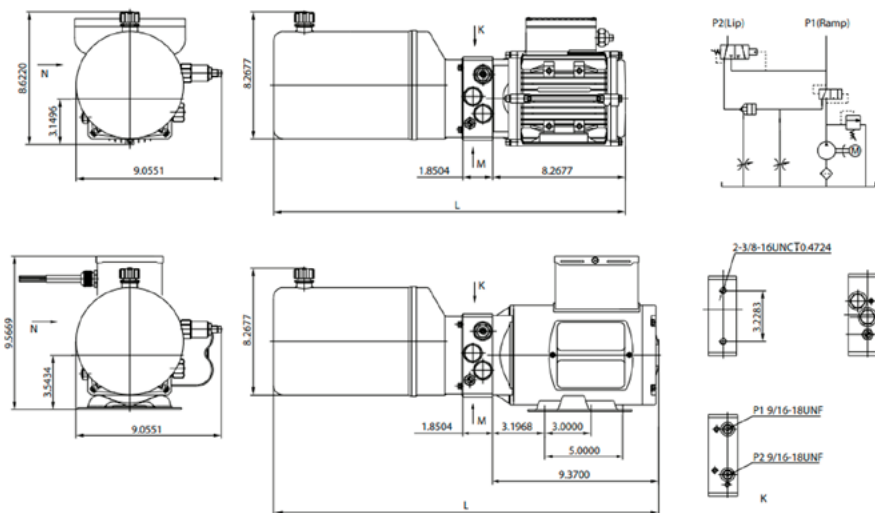

This platform leveler power unit raises the ramp when the motor is activated, when the ramp has reached the maximum extension level, the sequence changes to extend the lip. The ramp and lip are lowered by separate solenoid valves during lowering.

Both the ramp and lip lowering are controlled by a needle valve. The needle valves are adjustable to achieve the desired lowering speed of each function.

For filling the reservoir of the hydraulic unit, type AW /antiwear /antiwear) lubricants are recommended for tanks and industrial and mobile hydraulic equipment. Its use is recommended in mobile equipment where a fluid with hydraulic characteristics is required to help power transmission.

Advantages

- Excellent thermal and oxidation stability providing long equipment life.
- Prolonged performance that maintains operation in heavy duty hydraulic systems operating at high pressures, temperatures and speeds.
- Excellent dimulsibility.

The power unit is S3 duty, which can only be operated intermittently, 1 minute on and 9 minutes off.

Clean all affected hydraulic components before installation of the power unit.

The viscosity of the hydraulic oil should be 15 - 46 cst, it should be clean and free of impurities, ISO 68 hydraulic oil is recommended.

Check the oil level in the tank after initial operation of the power unit.



10. Inventory of parts

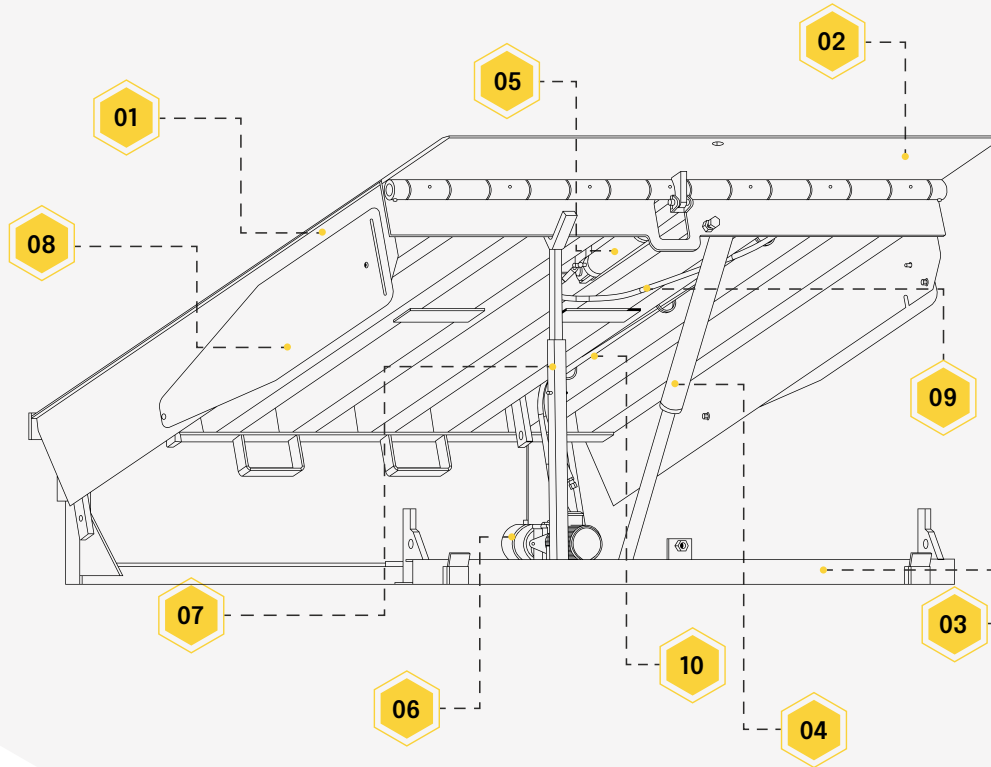

NO.	DESCRIPTION
01-	Hydraulic platform ramp platform
02-	Lip
03-	Base
04-	Platform Cylinder
05-	Lip Cylinder
06-	Hydraulic Unit
07-	Maintenance Bar
08-	Side Protection Guard
09-	Lip Cylinder Hose
10-	Platform Cylinder Hose

▶ 10.1 LIP LOWERING SPEED INCREASE.

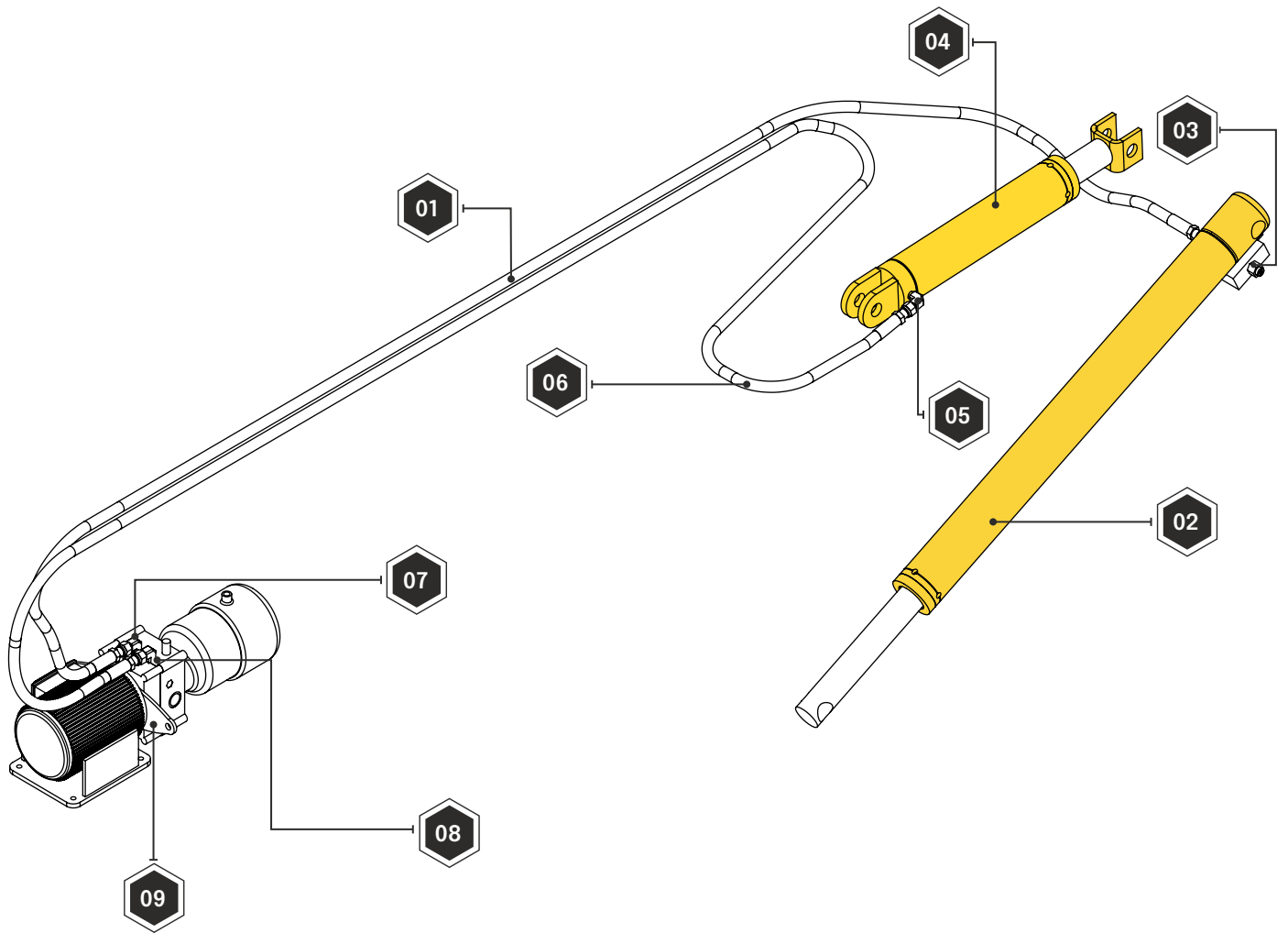

NUMBER	ELEMENT
01	PLATFORM CYLINDER HOSE
02	PLATFORM CYLINDER
03	PARACHUTE VALVE
04	LIP CYLINDER
05	90° ELBOW CONNECTION
06	LIP CYLINDER HOSE
07	90° ELBOW TYPE HYDRAULIC CONNECTION
08	METRIC TO NPT HYDRAULIC CONNECTION
09	HYDRAULIC UNIT

▶ 10.2 EXPLOSION OF HYDRAULIC LEVELER PARTS

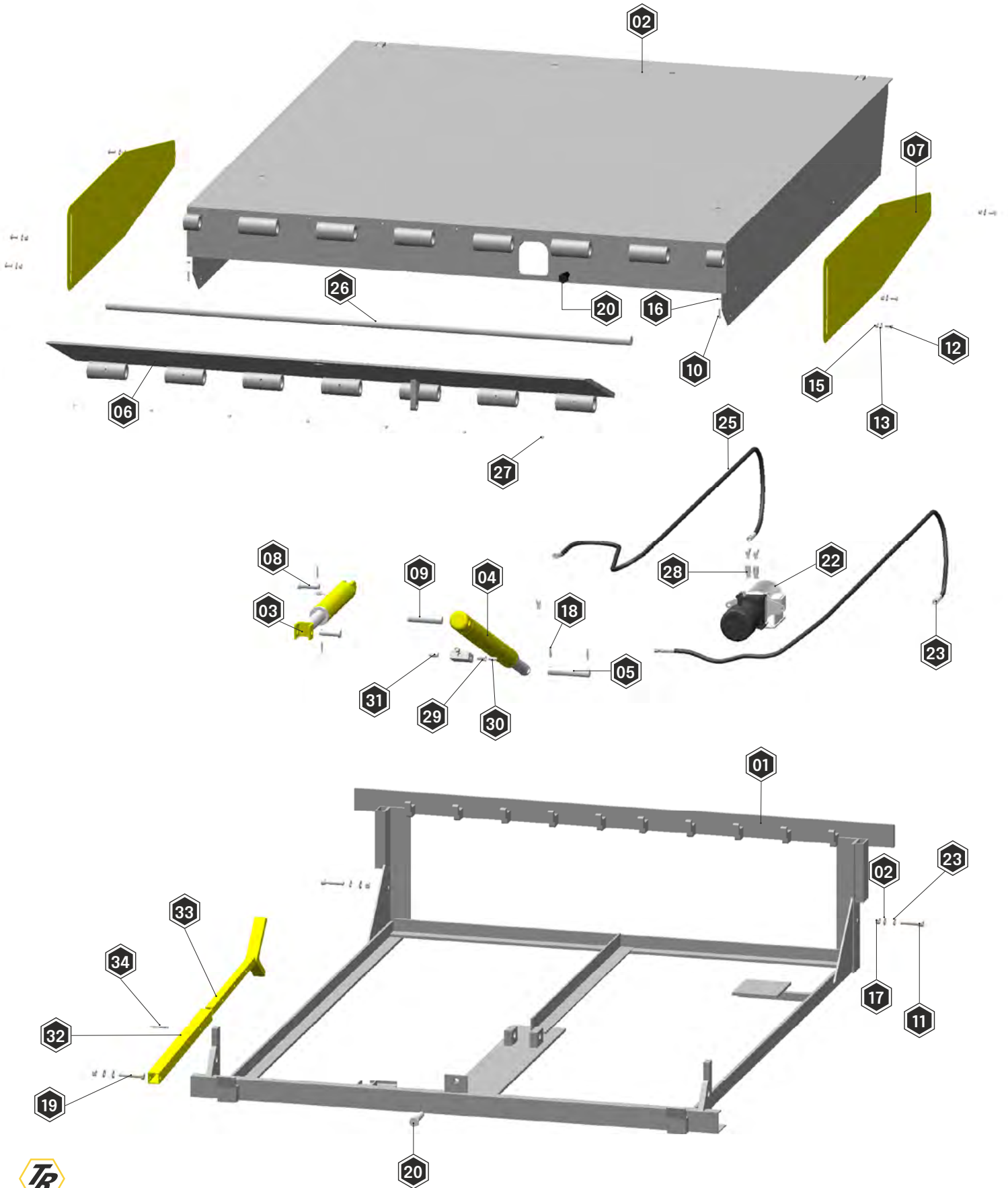

▶ 10.3 HYDRAULIC LEVELER PARTS LIST

ITEM	PART NAME	QUANTITY	30,000 LBS	CODE		
				40,000 LBS	50,000 LBS	
01	Base Structure	1	PART	RNH-ESTB		RNH-50-ESTB
02	Platform	1	PART	RNH30-PTF	RNH40-PTF	RNH50-PTF
03	Lip Cylinder	1	PART		RNH-ASSY-CIL-LAB	
04	Platform Cylinder	1	PART		RNH-ASSY-CIL-PTF	
05	Bolt 1"-115mm	1	PART		MPPER07	
06	Lip Plate	1	PART	RNH30-PLLA-XX*	RNH40-PLLA-XX*	RNH50-PLLA-XX*
07	Side Guard	2	PART		RN-GRDL-01	
08	Ch Bolt	2	PART		MAQ1380	
09	Platform Cylinder Bolt	1	PART		MPPER06	
10	Blued Allen Bolt	1/4"-28x1"	2	PART	MPTOR1153	
11	Blued Allen Screw	1/2"-20x2-1/2"	2	PART	MPTOR1256	
12	Allen Screw Drop Head	3/8"-16x1"	6	PART	MPTOR1371	
13	Flat Washer	3/8"	6	PART	MPTOR1004	
14	Flat Washer	1/2"	4	PART	MPTOR1003	
15	Hexagonal lock nut	3/8"-16	6	PART	MPTOR1105	
16	Blued Hexagonal Nut	1/4"-28	2	PART	MPTOR1100	
17	Hexagonal Lock Nut	1/2"-13	3	PART	MPTOR1013	
18	Slotted Cotter Bolt	1/4"x1-1/2"	4	PART	MPTOR1376	
19	Blued Hexagonal Bolt	1/2"-13x3"	1	PART	MPTOR1369	
20	Blued Hexagonal Bolt	3/4"-10x3-1/2"	1	PART	MPTOR1277	
21	Pressure Washer	1/2"	2	PART	MPTOR1234	
22	Hydraulic Unit 1HP		1	PART	MPH2011 (MAQ1367)	
23	Cylinder Hose Platform		1	PART	MPHC2047	
24	90° Elbow Connection JIC-NPT	1/4"NPT-1/4"JIC	4	PART	MPHC1038	
25	Cylinder Hose Lip		1	PART	MPHC2047	
26	Hinge Bolt		1	PART	MPPER05	
27	Grease Fitting	1/8" NPT	7	PART	MPTOR1493	
28	Straight Coupling	M14 - 1/4" NPT	2	PART	MPHC1016	
29	NPT Reduction	1/2"NPT-1/4"NPT	2	PART	MPHC2041	
30	Straight NPT - JIC	1/4"NPT-1/4"JIC	1	PART	MPHC1040	
31	Safety Valve (Parachute)		1	PART	MPHI1008	
32	Maintenance Rod Liner		1	PART	RNM-BASM01	
33	Maintenance Rod Lock		1	PART	RNM-BASM02	
34	Maintenance Rod Bolt	3/8" x 2-1/2"	1	PART	MPPER1153	

* Replace XX with the lip size corresponding to your ramp model (16,18,20 or 22).

▶ 10.4 SPARE PARTS

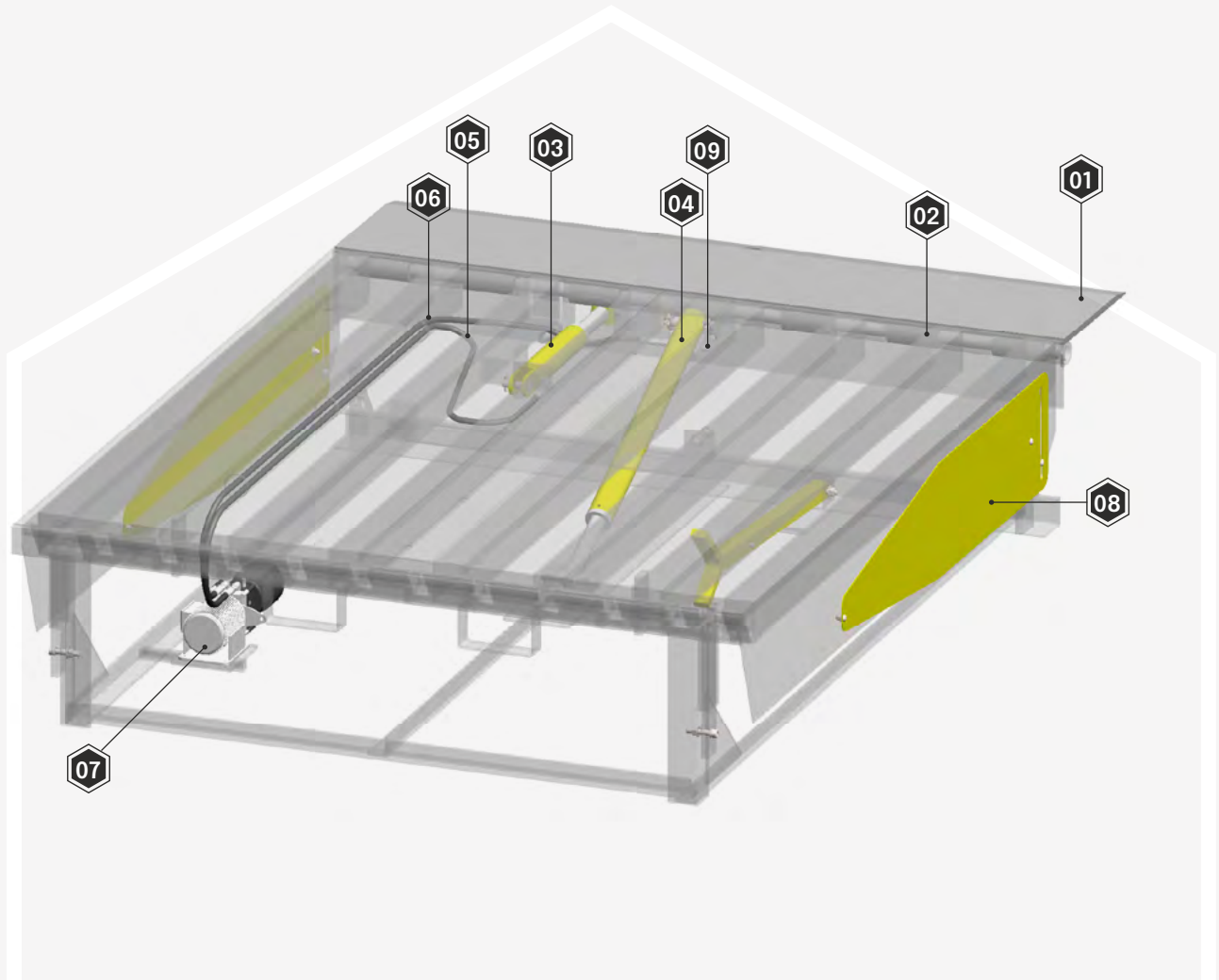

ELEMENT NUMBER	DESCRIPTION	CODE		
		RNH306X8	RNH406X8	RNH506X8
01	Lip Plate	RNH30-PLLA-XX*	RNH40-PLLA-XX*	RNH50-PLLA-XX*
02	Lip Hinge Bolt		RNM-PERB-01	
03	Lip Cylinder		RNH-ASSY-CIL-LAB	
04	Platform Cylinder		RNH-ASSY-CIL-PTF	
05	Lip Cylinder Hose		MPHC2047	
06	Platform Cylinder Hose		MPHC2047	
07	Hydraulic Unit		MPH2011 (MAQ1367)	
08	Side Guard Guard		RN-GRDL-01	
09	Parachute Valve		MPHI1008	

* Replace "XX" with the lip size corresponding to your ramp model (16, 18, 20 or 22).



▶ 10.5 MECHANICAL PLATFORM RAMP DECAL

CODE	DESCRIPTION	QTY	PICTURE
------	-------------	-----	---------

CAL1129	WARNING DECAL	004	
---------	---------------	-----	--



CAL1122	DANGER DECAL	001	
---------	--------------	-----	--



CAL1132	RAMP SAFETY DECAL	001	
---------	-------------------	-----	--



CAL1135	SECURITY BAR WARNING STICKER	001	
---------	------------------------------	-----	--

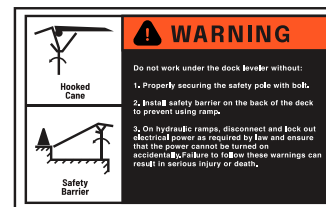

CAL1134	TECNORAMPA DECAL	001	
---------	------------------	-----	--



▶ 10.6 VISUAL AID MECHANICAL PLATFORM RAMP DECALS

— LABELS LEFT SIDE



— LABELS RIGHT SIDE

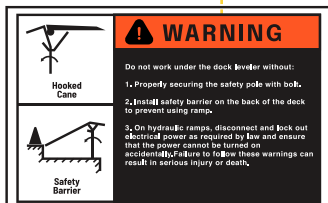



TecnoRampaTM



EMPRESA CERTIFICADA



TECNORAMPA S.A. de C.V.

Lada sin costo
01 800 6230 332 / 01 800 8380 850
01 (427) 272 81 19 / 01 (427) 272 4041

Tecnorampa USA
1586 N Goldenrod Road,
Orlando, Florida

www.tecnorampa.us